

Impingers train configurations

Introduction:

The impingers train has a double scope:

- 1) cool down and condense the water fraction and
- 2) protect the isokinetic pump.

Our suggestion is to use always 4 impingers train + 1 lt silica gel trap for efficiency/safety reasons. Most of the service carried out on the isokinetic sampling pump is because of water presence inside the pump.

The international standards:

To define the impinger train configuration, it's better to divide the international standards in categories related to parameters.

Particulate Matter:

EN13284-1

refers to the **EN14790** for water content determination.

The **EN14790** defines the cooling and condensing system as follows:

5.5 Trapping unit

The trapping unit shall be made up with:

— an absorption unit

— or a condensation and an absorption unit

- a) *When using the absorption unit alone, it shall consist of at least one cartridge, impinger or bubbler, filled with a suitable drying agent, for example: coloured silica gel*
- b) *The condensation and absorption unit shall consist of two stages:*
 - 1) *the first one shall be a condensation stage with a suitable cooling*
 - 2) *the second one shall be an absorption stage as described in a).*

The temperature at the outlet of the condensation unit shall be as low as possible.

The efficiency of the sampling system shall be checked periodically by placing an additional absorber unit after the trapping unit in its normal configuration and by measuring the weight of water collected in it. The quantity q_2 of water collected in this additional absorber shall be less than 10% of the water collected in the entire sampling unit. It means that the absorption efficiency e of the trapping unit shall be better than 90 %.

Efficiency of the sampling system is $= q_1 / (q_1 + q_2)$

Note The trapping efficiency can be increased by increasing the residence time of sampled gases in the trapping unit and/or by improving the efficiency of the cooling system. The sampled volume should be sufficient to reach an appropriate accuracy of the measurement (see clause 7).

Condensation of water shall be avoided in all parts of the sampling system that are not weighed.

Summarizing, this standard offers for two possible solutions

- 1) Low water content: 1 lt silica gel trap
- 2) High water content: Impinger train + 1 lt silica gel trap

Actually, nor EN13284 or EN14790 specify which type of impingers have to be used in the train. EN14790 shows a train of two impingers and suggest a third impinger for the efficiency evaluation. Last impinger, the n° 4, is for protection.

We always suggest a train of 4 impingers to include all possibilities.

Our standard configuration is for 2 plate impingers and 2 free tube impingers. This configuration is compact inside the athermal box but it's possible to adopt other configurations.

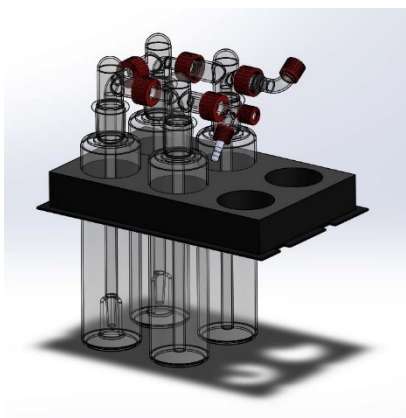

Example of impinger train for water condensation

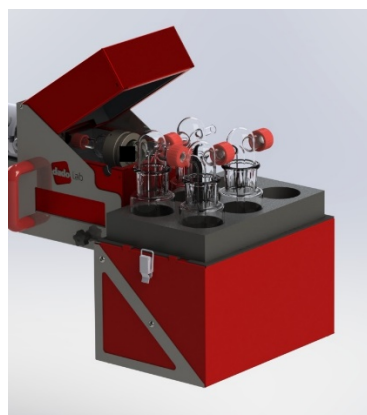

The athermal box installed on the HP5 probe

p/n	Description	Q.ty
101 103 2010	500cc free tube impinger	2
101 103 2011	500cc plate impinger	2
101 103 2012	GL25/GL18 90° Elbow connector	1
101 103 2013	Outlet gas 90° Elbow connector	1

In case the water content is “very” low, below 5%, than it’s possible to use the silica gel trap only .



The 1 Lt Silica Gel trap

EN16510 Method

This is a new method for particulate matter determination on domestic burners. Practically is a variation of the EN13284 sampling line, just requesting for very short heated probes (0,5 – 1.0 mt). In this method is requested only the 1 Lt Silica Gel trap.

Alternative solutions

Many laboratories were requesting an alternative solution to glass impingers, in particular, safer for technicians, rugged and shock resistant and easier to manage. Following this request, Dado lab realized the Polycarbonate impingers which are reliable and convenient.

Note:

No actual method is specifying polycarbonate as material for the Impingers.

EN14970 isn't excluding the possibility to use other materials for the condensing impingers.

Polycarbonate impingers can be surely used for water condensation in the particulate matter sampling lines (EN13284/EPA 5).

PC impingers have a very high resistance to inorganic aggressive compounds, such as strong acids/basis (HCl, HNO₃, NaOH, NH₃) up to 20% in volume but are quite weak with organic solvents so contact with Toluene, Acetone etc. They are not suitable for PAH, VOCs sampling.

For other methods, such as Heavy metals, equivalency has to be demonstrated.



500cc Polycarbonate impinger



250cc Polycarbonate impinger

More information about polycarbonate impingers can be found on the product data.

Heavy Metals

EN14385 (US EPA M29)

Despite to their US EPA equivalent, the EN14385 for heavy metals determination offers the possibility to assemble the sampling line with 1) main isokinetic stream or 2) side sampling stream.

Also other EN methods, such as EN1911 for HCl or EN14791 for Sox or EN15765 for Fluorides, offer this possibility and we will see them later on.

EN14385 for heavy metals

Sampling line on main isokinetic stream

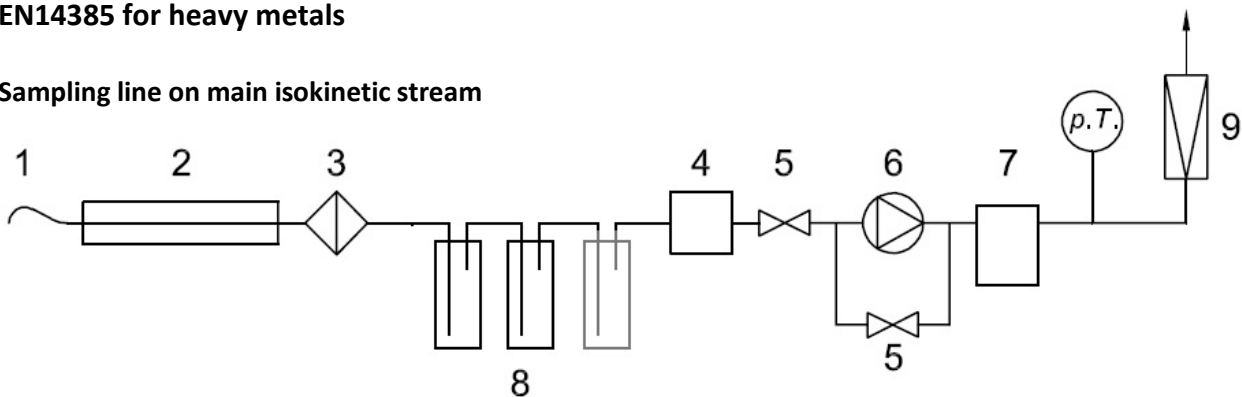

1	Nozzle	5	Valve	9	Gas flow meter
2	Probe	6	Pump	T	Temperature
3	Filter (either behind or in front of the probe)	7	Gas volume meter*	p	Pressure measure
4	Dryer cartridge	8	Impingers*		

* Point n° 8 - Impingers:

Same EN13284-1 Impingers train (4 impingers) can be used for this configuration.

Off topic note:

EN14385 Ch. 5.1.2.7 – Gas Volume Metering

Two gas volume measuring methods may be used:

- 1) Gas Flow Measurement (Method 1 -)
- 2) Gas Flow Measurement (Method 2)

Both methods are described in EN13284-1.

Method 2 (orifice meter) is more accurate than method 1 (DGM)

EPA M29 for Heavy metals

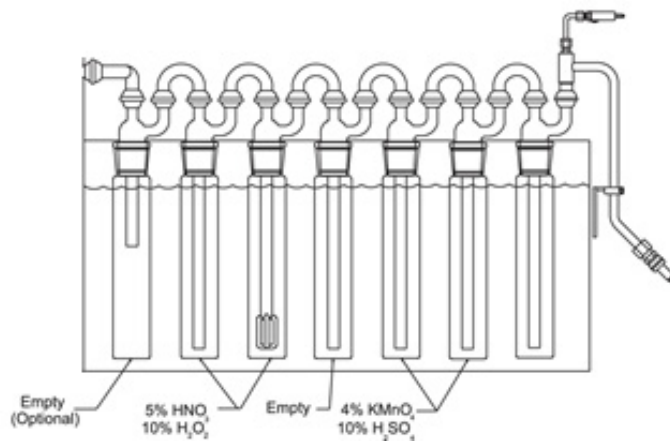

The EPA29 method is very similar to EN14385, just change the number of impingers:

p/n	Description	Q.ty
101 103 2010	500cc free tube impinger	3
101 103 2011	500cc plate impinger	2
101 103 2012	GL25/GL18 90° Elbow connector	1
101 103 2013	Outlet gas 90° Elbow connector	1

Free tube Impinger n° 1 – 2 – 5

Plate Impingers n° 3 - 4

EN14385 for side sampling

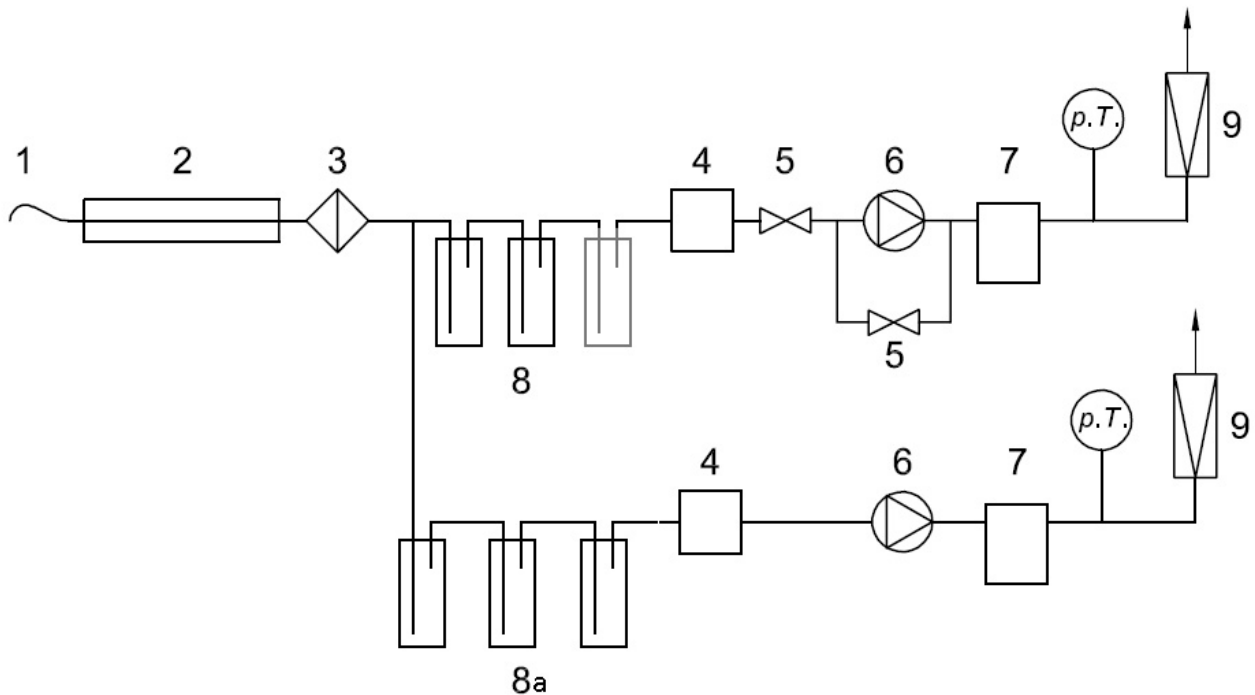

- | | | | | | |
|---|---|---|------------------|----|-------------------------|
| 1 | Nozzle | 5 | Valve | 8a | Side stream impingers** |
| 2 | Probe | 6 | Pump | 9 | Gas flow meter |
| 3 | Filter (either behind or in front of the probe) | 7 | Gas volume meter | T | Temperature |
| 4 | Dryer cartridge | 8 | Impingers* | p | Pressure measure |

N°8 : Main stream impingers

This impinger train is usually composed by 3 500cc free tube impingers (Midget impinger alike)

p/n	Description	Q.ty
101 103 2010	500cc free tube impinger	3
101 103 2012	GL25/GL18 90° Elbow connector	1
101 103 2013	Outlet gas 90° Elbow connector	1

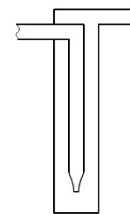

N°8a : Side stream impingers

This train is composed by 3 250cc impingers with Schott fittings.

p/n	Description	Q.ty
101 103 2015	250cc free tube impinger w/ Schott	3

We suggest to use those impingers without the frit because it becomes clogged after few uses and it's difficult to clean, eventually we can supply also the frit version:

p/n	Description	Q.ty
101 103 2019	250 cc Side Sampling Impinger w/frit	3

The Side Sampling Kit

a kit for the single side sampling is available on the price list with p/n **101 103 2050** and includes:

Q.ty Description

- 1 Mousse and support for 500cc impingers
- 3 500cc free tube impinger
- 1 GL25/GL18 90° Elbow connector
- 1 Outlet gas 90° Elbow connector
- 3 250 cc Side Sampling Impinger
- 1 FC5 Outlet T connector w/ temp sensor inlet
- 1 PVDF Ball valve for derived line

Impingers train for **EN1911** for HCl and **EN14791** for Sox are identical to **EN14395**

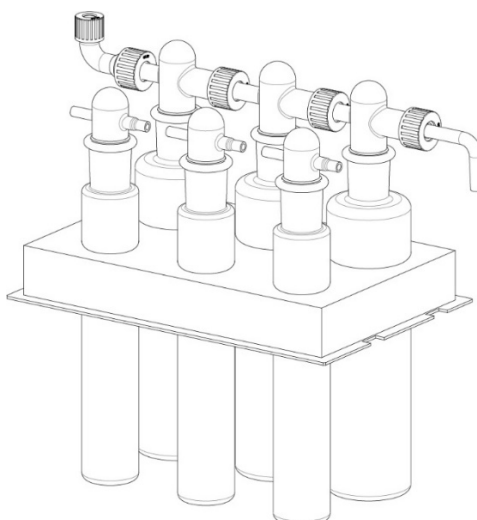

Main isokinetic + Side stream in the athermic box

Mercury

EN13211 and US Ontario Hydro Method

Like for heavy metals, the EN13211 for Mercury determination includes both main isokinetic and side sampling solutions.

The equivalent US method, called Ontario Hydro Method (OHM) ask for the main isokinetic stream only.

EN13211 on Main isokinetic stream

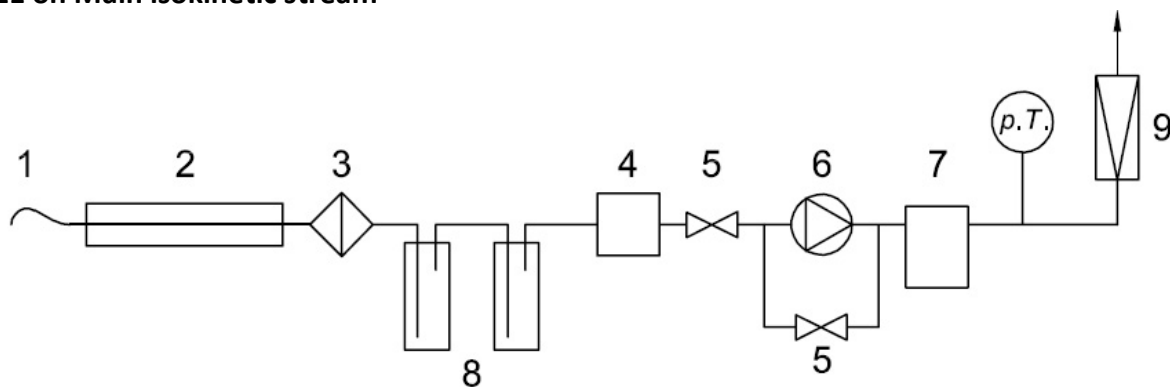

p/n	Description	Q.ty
101 103 2010	500cc free tube impinger	2
101 103 2011	500cc plate impinger	2
101 103 2012	GL25/GL18 90° Elbow connector	1
101 103 2013	Outlet gas 90° Elbow connector	1

As before, in the impingers train we include the “efficiency impinger” and the protection one.

Ontario Hydro Method

This method requires 6 impingers + 1 for silica gel

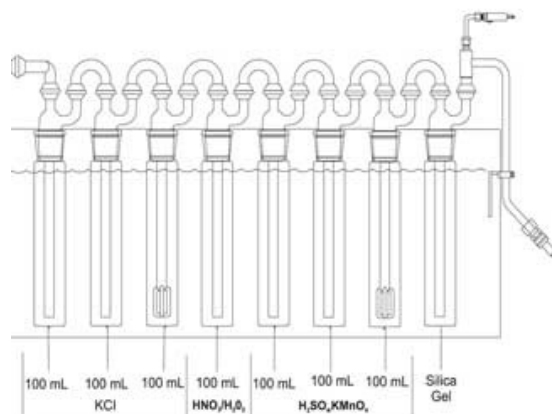

This solution is realized using two athermal boxes fixed on the HP5 probe through a special support "cube":

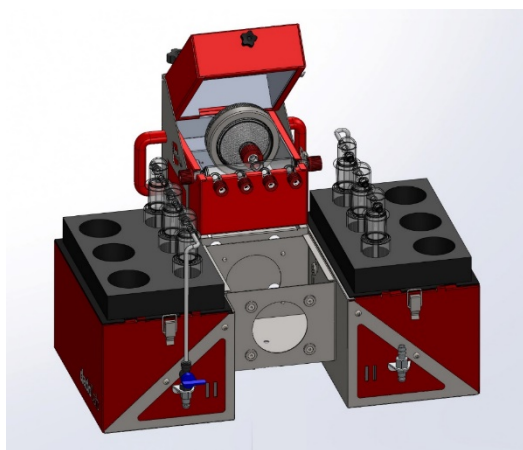

Impingers train composition

p/n	Description	Q.ty
101 103 2010	500cc free tube impinger	5
101 103 2011	500cc plate impinger	2
101 103 2012	GL25/GL18 90° Elbow connector	1
101 103 2013	Outlet gas 90° Elbow connector	1

EN13211 on side sampling

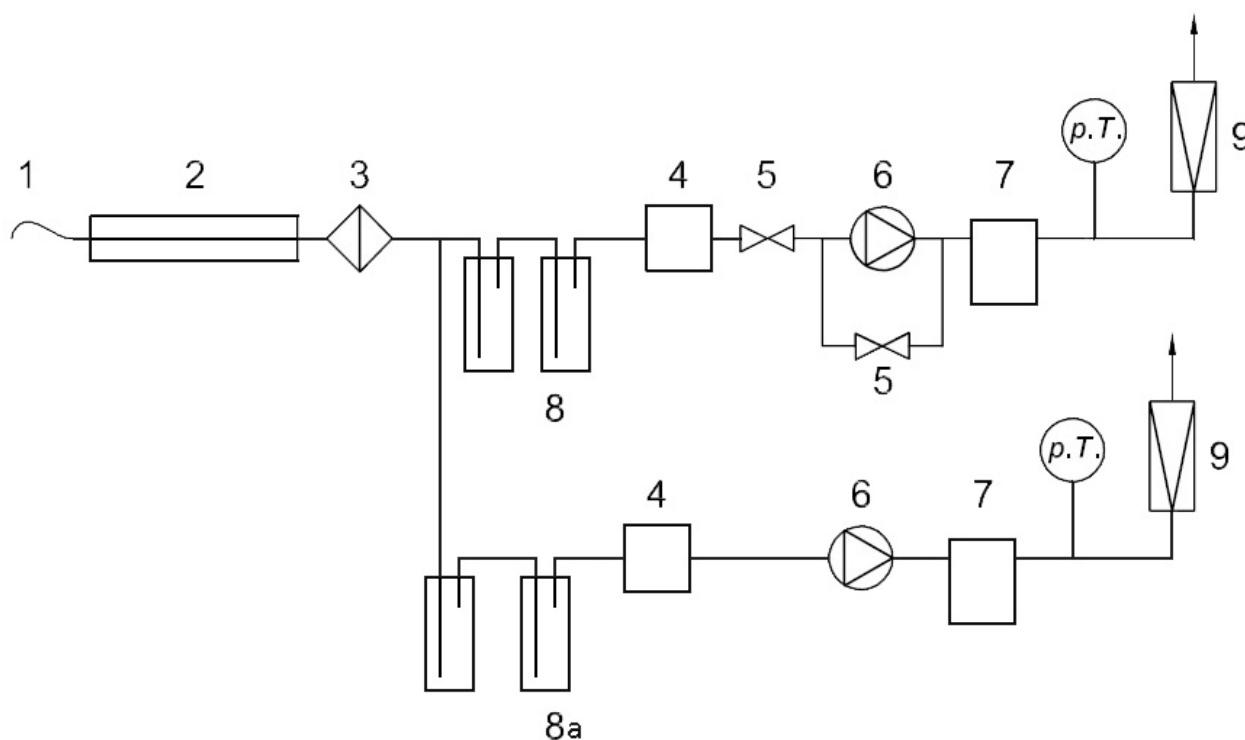

Main stream

p/n	Description	Q.ty
101 103 2010	500cc free tube impinger	3
101 103 2012	GL25/GL18 90° Elbow connector	1
101 103 2013	Outlet gas 90° Elbow connector	1

Side Stream

p/n	Description	Q.ty
101 103 2015	250cc free tube impinger w/ Schott	2

EN15713 – Determination of Fluorides

Because this family of compounds are particularly aggressive, usual impingers made of glass cannot be used. The standard asks for Quartz or Polyethylene impingers.

Compared to quartz, polyethylene impingers are far more robust and and cost effective, this is why all customers chose this type of solution.

The standard is asking for the isokinetic sampling line realized on main stream but there are some practical difficulties (low flowrates, volume of the impingers...) which push the choice to side sampling configuration.

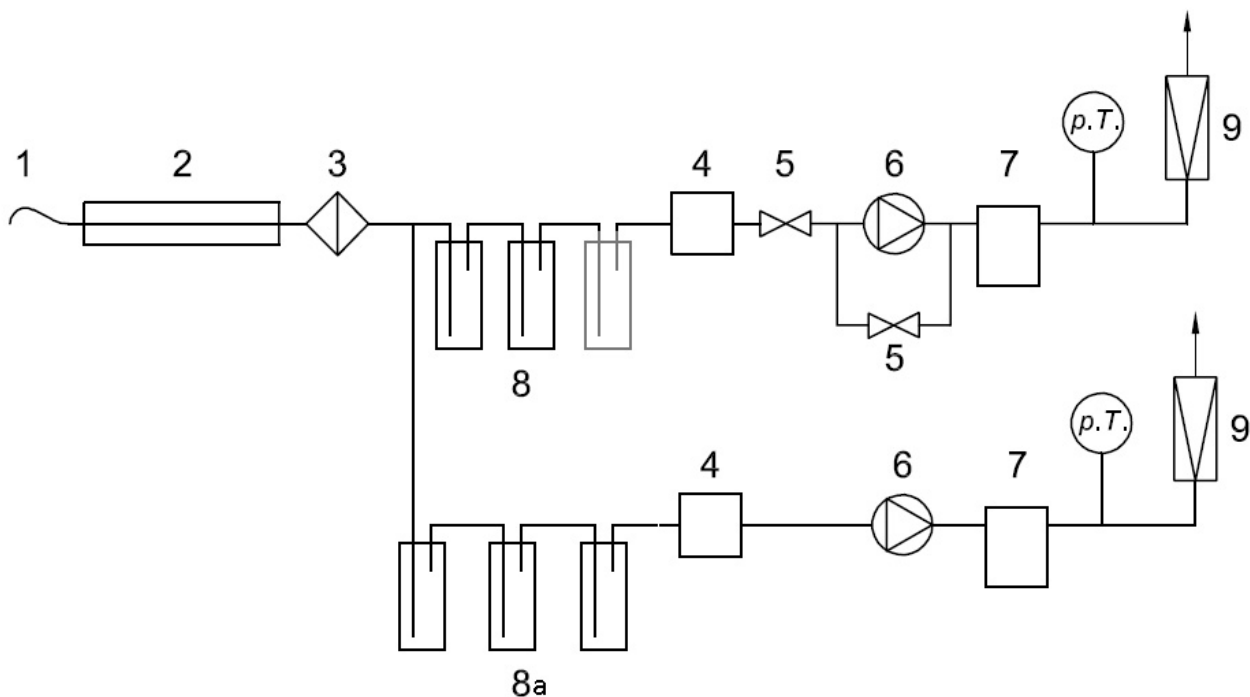

Main stream (n° 8)

p/n	Description	Q.ty
101 103 2010	500cc free tube impinger	3
101 103 2012	GL25/GL18 90° Elbow connector	1
101 103 2013	Outlet gas 90° Elbow connector	1

Side Stream (8a)

p/n	Description	Q.ty
101 103 2026	250cc PE impingers	3

EPA 16A – Total Reduced Sulphur

This method is dedicated to the determination of the TRS from stationary sources (<https://www3.epa.gov/ttnemc01/promgate/m-16a.pdf>) for the following compounds:

Total reduced sulfur (TRS) including

Dimethyl disulfide [(CH₃)₂S₂]

Dimethyl sulfide [(CH₃)₂S]

Hydrogen sulfide [H₂S]

Methyl mercaptan [CH₄S]

Reduced sulfur (RS) including:

H₂S

Carbonyl sulfide [COS]

Carbon disulfide [CS₂]

Reported as: Sulfur dioxide (SO₂) 7449-09-5

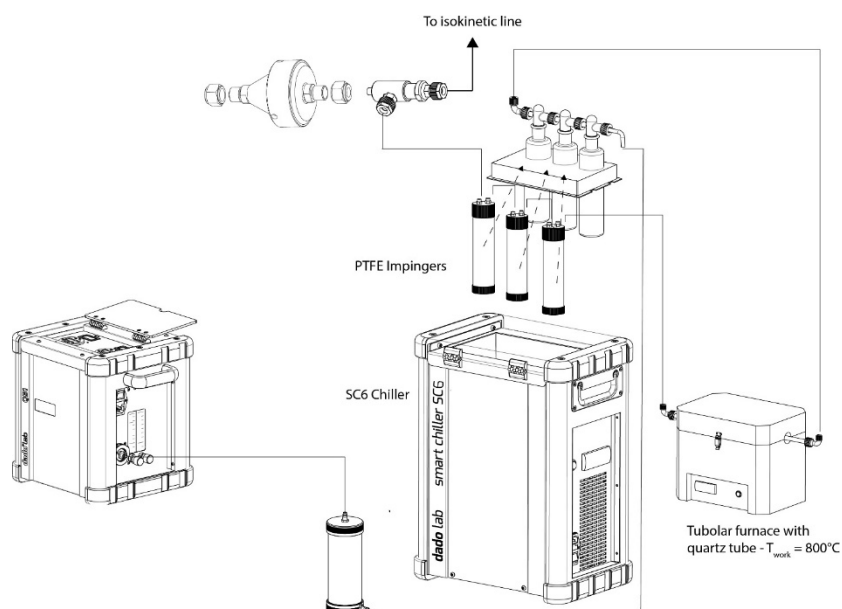

Sampling line is realized on the derivation after filter and sample is taken first to 3 PTFE impingers, first two filled with 100 ml pf Citrate buffer and the third left empty. Flue gas will then be heated up to 800°C in the combustion tube (a tubular furnace is required) and then taken to the second impingers train containing H₂O₂. Both trains are cooled down in the SC6 chiller.

PTFE Impingers

p/n	Description	Q.ty
101 103 2025	250cc PTFE impingers	3